

# HSMx-A46x-xxxxx

## SMT LED Surface Mount LED Indicator



### Data Sheet



#### Description

The Power PLCC-4 SMT LED with Lens are high performance PLCC-4 package size SMT LEDs targeted mainly in Automotive & Electronics Signs and Signals (ESS) markets. These top-mount single-chip packages with focused radiation offer high brightness in beam direction and are excellent for interior automotive, indoor and outdoor sign and industrial applications. With additional lens in 50° variants, these products are especially fitting to applications for Mono-color Text Display, CHMSL and displays.

The PLCC-4 package family is able to dissipate heat better compared to the PLCC-2 packages. In proportion to this increase in driving current, this family of LEDs is able to produce higher light output compared to the conventional PLCC-2 SMT LEDs.

As an extension of the standard flat top PLCC-4 SMT LEDs, the Power PLCC-4 with Lens device is able to provide focused beams within narrow viewing angles (50°) meeting the market's requirements for focused radiation and high brightness in beam directions.

The Power PLCC-4 SMT LED with 50° is ideal for panel, push button, general backlighting, automotive interior & exterior (cluster backlighting, side repeaters, brake lights), sign and symbol illumination, office equipment, industrial equipment and home appliances applications. This package design coupled with careful selection of component materials allow the Power PLCC-4 SMT LED with Lens to perform with higher reliability in a larger temperature range -40°C to 100°C. This high reliability feature is crucial to allow the Power PLCC-4 SMT LED with Lens to do well in harsh environments such as its target Automotive & ESS markets. The Power PLCC4 SMT LED with Lens package is also designed to be compatible with both IR-solder re-flow and through-the-wave soldering.

#### Features

- Industry standard PLCC-4
- High reliability LED package
- High brightness using AllnGaP dice technologies
- High optical efficiency
- Narrow Viewing angle at 50°
- Available in 8mm carrier tape on 7-inch reel

#### Applications

- Interior automotive
  - Instrument panel backlighting
  - Central console backlighting
  - Cabin backlighting
  - Navigation and audio system
  - Dome lighting
  - Push button backlighting
- Exterior automotive
  - Turn signals
  - CHMSL
  - Rear combination lamp
  - Side repeaters
- Office automation, home appliances, industrial equipment
  - Front panel backlighting
  - Push button backlighting
  - Display backlighting

## Package Drawing

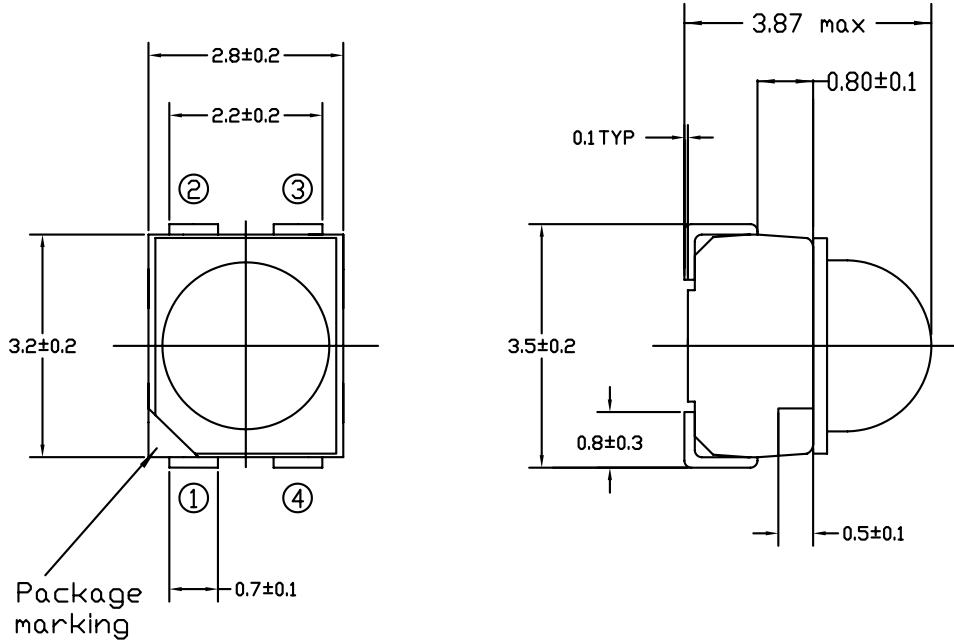

Note:

1. All Dimensions in millimeters.
2. Terminal Finish: Ag plating
3. Electrical connection between all cathode is recommended

Figure 1. Package Drawing

Pin	HSMx-A46x Lead Configuration
1	Cathode
2	Anode
3	Cathode
4	Cathode

Table 1. Device Selection Guide

Color	Part Number	Luminous Intensity, $\Phi_V$ [1] (mcd)			Test Current (mA)	Dice Technology
		Min. Iv (mcd)	Typ. Iv (mcd)	Max. Iv (mcd)		
Amber	HSMA-A460-W50M1	1125	2100	3550	50	AllnGaP
Amber	HSMA-A461-X83M1	2240	3300	5600	50	AllnGaP
Red	HSMC-A460-U30M1	450	580	900	50	AllnGaP
Red	HSMC-A461-V00M1	715	1750	-	50	AllnGaP
Orange	HSML-A461-W40M1	1125	1850	2850	50	AllnGaP

Notes:

1. The luminous intensity  $I_V$ , is measured at the mechanical axis of the lamp package. The actual peak of the spatial radiation pattern may not be aligned with this axis.
2. Tolerance =  $\pm 12\%$

## Part Numbering System

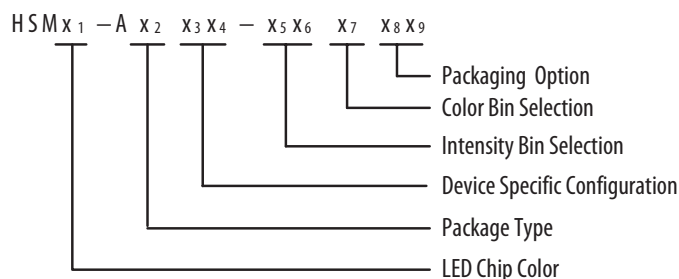

**Table 2. Absolute Maximum Ratings ( $T_A = 25^\circ\text{C}$ )**

Parameters	HSMA/C/L
DC Forward Current <sup>[1]</sup>	70 mA
Peak Forward Current <sup>[2]</sup>	200 mA
Power Dissipation	180 mW
Reverse Voltage	5 V
Junction Temperature	110°C
Operating Temperature	-40 °C to +100 °C
Storage Temperature	-40 °C to +100 °C

Notes:

1. Derate Linearly as shown in Figure 6.
2. Duty Factor = 10%, Frequency = 1kHz

**Table 3. Optical Characteristics ( $T_A = 25^\circ\text{C}$ )**

Color	Part Number	Dice Technology	Peak Wavelength	Dominant Wavelength	Viewing Angle	Luminous Efficacy	Luminous Efficiency	Luminous Intensity/ Total Flux
			$\lambda_{\text{PEAK}}$ (nm)	$\lambda_{\text{D}}$ <sup>[1]</sup> (nm)	$2\theta_{1/2}$ <sup>[2]</sup> (Degrees)	$\eta_{\text{V}}$ <sup>[3]</sup> (lm/W)	$\eta_{\text{e}}$ (lm/W)	$I_{\text{V}}$ (cd) / $\Phi_{\text{V}}$ (lm)
			Typ.	Typ.	Typ.	Typ.	Typ.	Typ.
Amber	HSMA-A46x	AllnGaP	592	590	50	480	22	1.35
Red	HSMC-A46x	AllnGaP	635	626	50	150	19	1.15
Orange	HSML-A46x	AllnGaP	609	605	50	320	23	1.05

Notes:

1. The dominant wavelength,  $\lambda_{\text{D}}$ , is derived from the CIE Chromaticity diagram and represents the color of the device.
2.  $\theta_{1/2}$  is the off-axis angle where the luminous intensity is  $1/2$  the peak intensity.
3. Radiant intensity,  $I_{\text{e}}$  in watts / steradian, may be calculated from the equation  $I_{\text{e}} = I_{\text{V}} / \eta_{\text{V}}$ , where  $I_{\text{V}}$  is the luminous intensity in candelas and  $\eta_{\text{V}}$  is the luminous efficacy in lumens / watt.
4.  $\Phi_{\text{V}}$  is the total luminous flux output as measured with an integrating sphere after the device has stabilized.
5. Flux tested at mono pulse conditions.

**Table 4. Electrical Characteristics ( $T_A = 25^\circ\text{C}$ )**

Part Number	Forward Voltage $V_{\text{F}}$ (Volts) @ $I_{\text{F}} = 50 \text{ mA}$		Reverse Voltage $V_{\text{R}}$ @ $100 \mu\text{A}$	Thermal Resistance $R_{\theta_{\text{J-P}}}$ ( $^\circ\text{C}/\text{W}$ )
	Typ.	Max.	Min.	
HSMA-A46x	2.20	2.50	5	110
HSMC-A46x	2.20	2.50	5	110
HSML-A46x	2.20	2.50	5	110

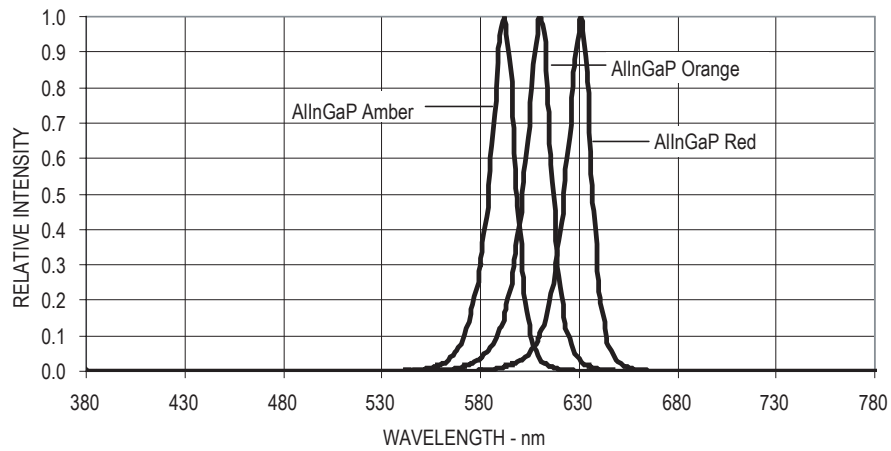

Figure 2. Relative Intensity Vs. Wavelength

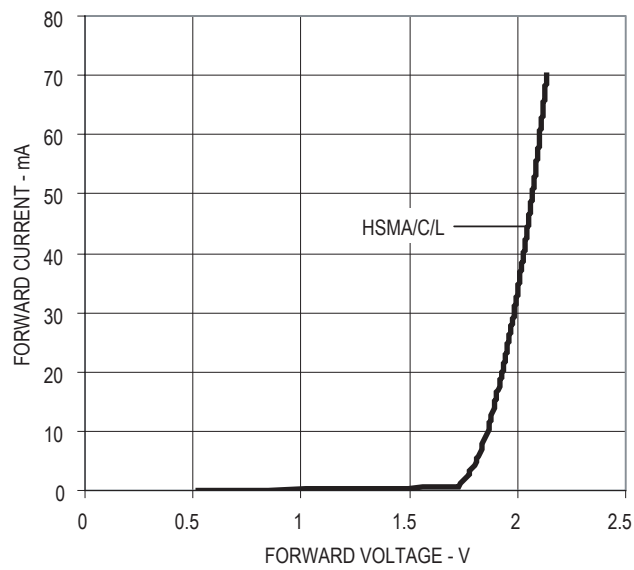

Figure 3. Forward Current Vs. Forward Voltage.

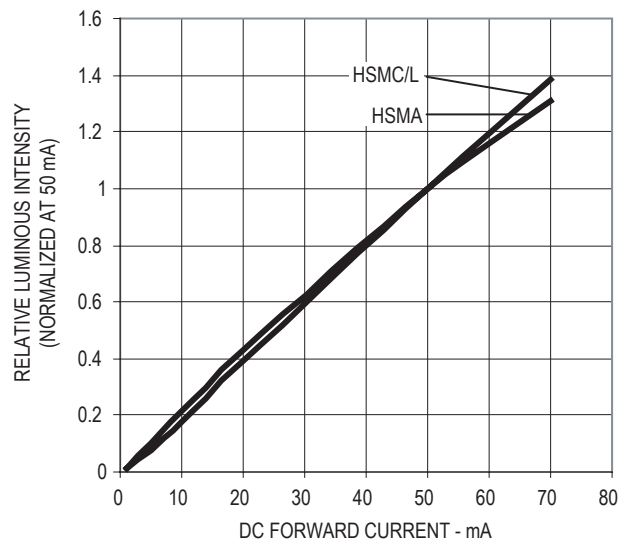

Figure 4. Relative Intensity Vs. Forward Current

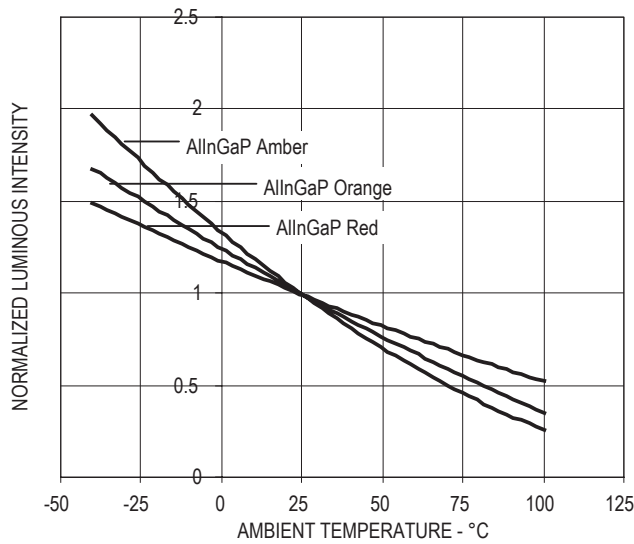
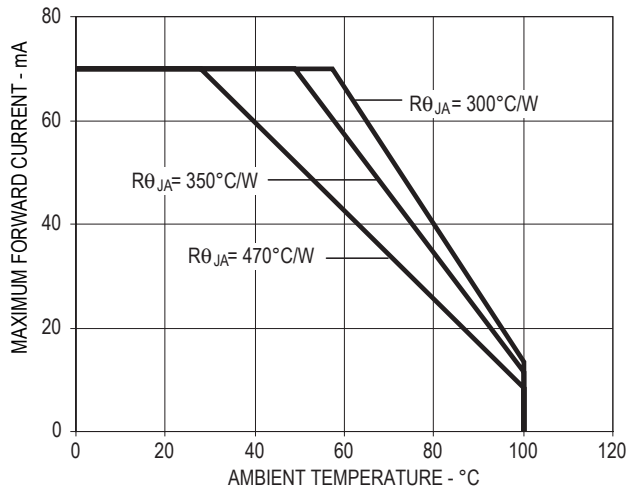
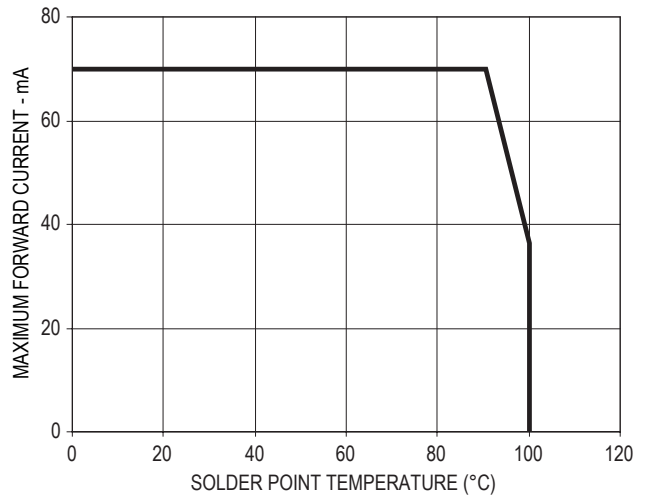

Figure 5. Relative Intensity Vs. Temperature



**Figure 6a. Maximum Forward Current Vs. Ambient Temperature.**  
 Derated Based on  $T_{JMAX} = 110^\circ\text{C}$ ,  $R_{\theta JA} = 300^\circ\text{C/W}$ ,  $350^\circ\text{C/W}$  and  $470^\circ\text{C/W}$ .



**Figure 6b. Maximum Forward Current Vs. Solder Point Temperature.**  
 Derated Based on  $T_{JMAX} = 110^\circ\text{C}$ ,  $R_{\theta JP} = 110^\circ\text{C/W}$ .

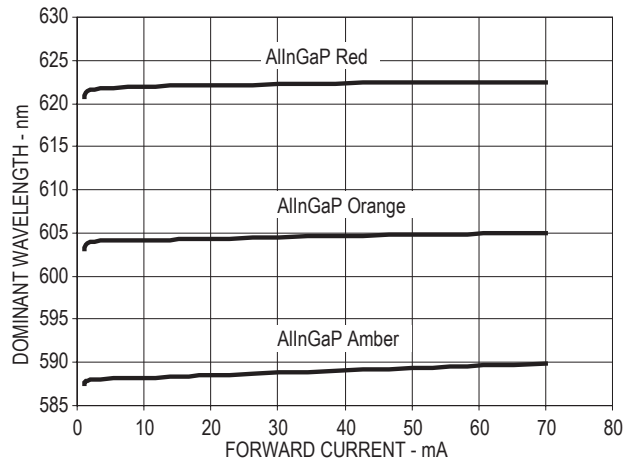

**Figure 7. Dominant Wavelength Vs. Forward Current.**

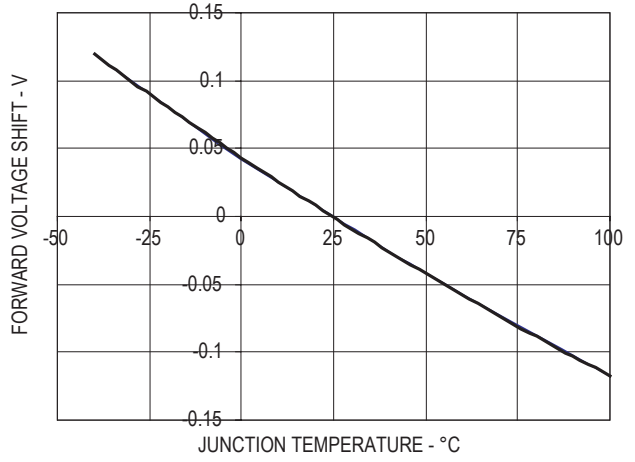

**Figure 8. Forward Voltage Shift Vs. Temperature.**

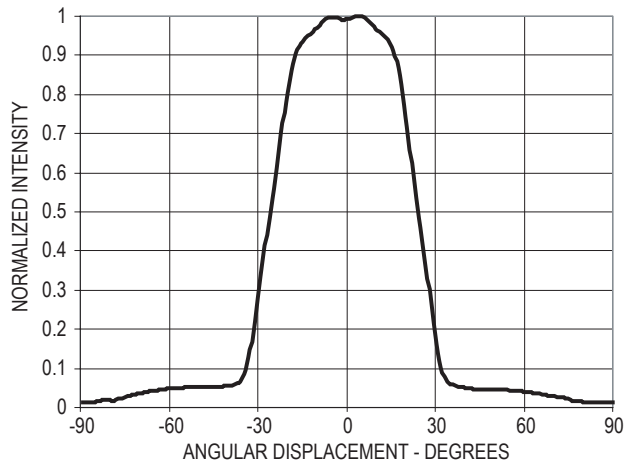

**Figure 9. Radiation Pattern**

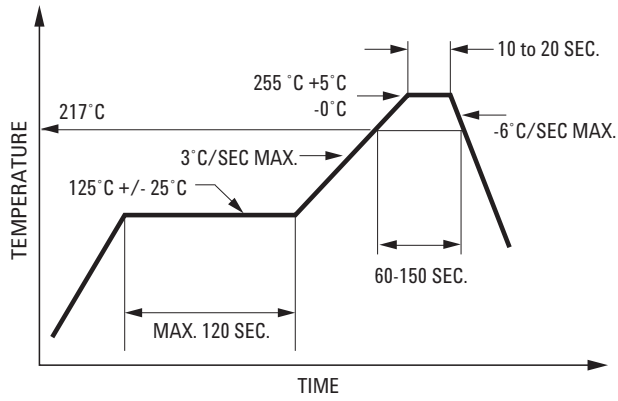

Figure 10. Recommended Pb-free Reflow Soldering Profile.

Note: For detail information on reflow soldering of Avago surface mount LEDs, do refer to Avago Application Note AN 1060 Surface Mounting SMT LED Indicator Components.

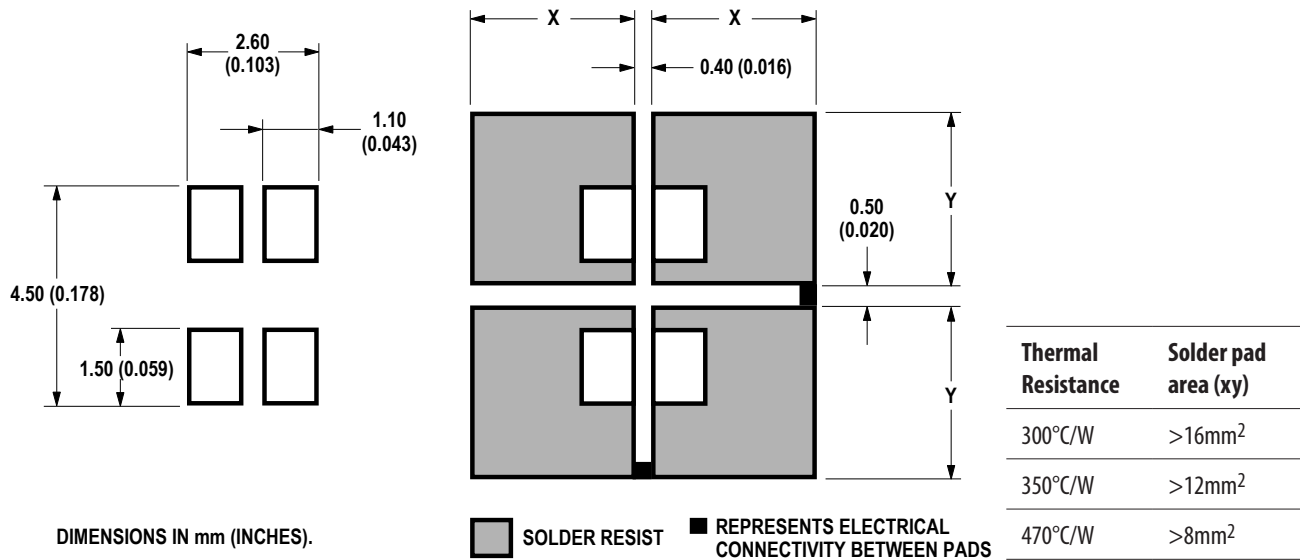

Figure 11a. Recommended Soldering Pad Patter

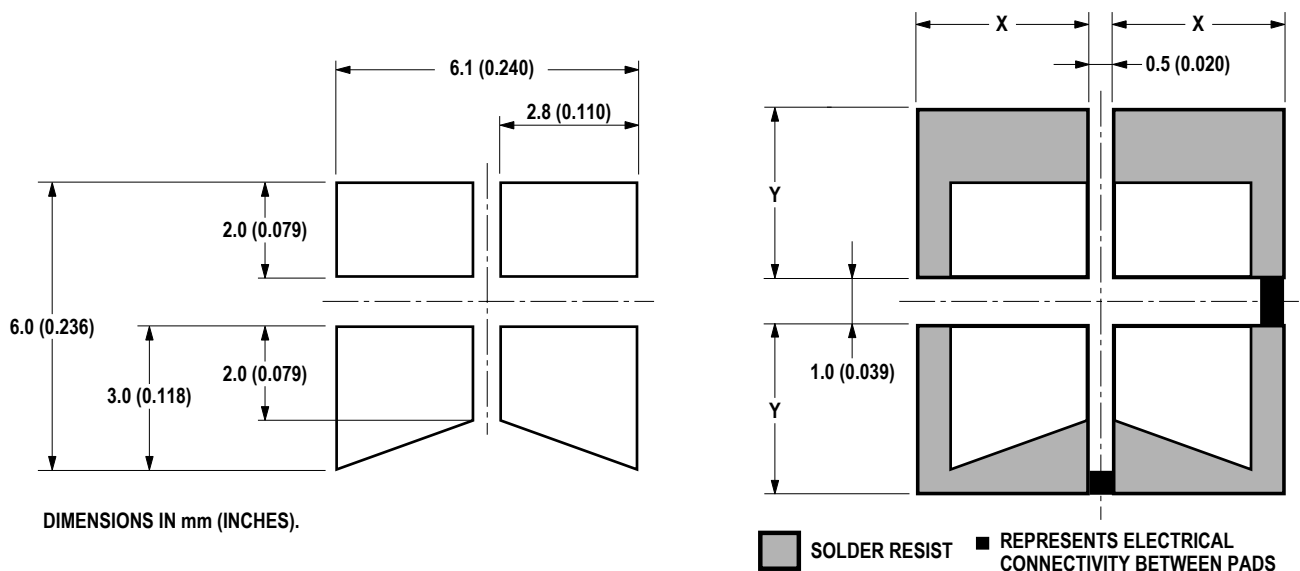

Figure 11b. Recommended Soldering Pad Patter (TTW)

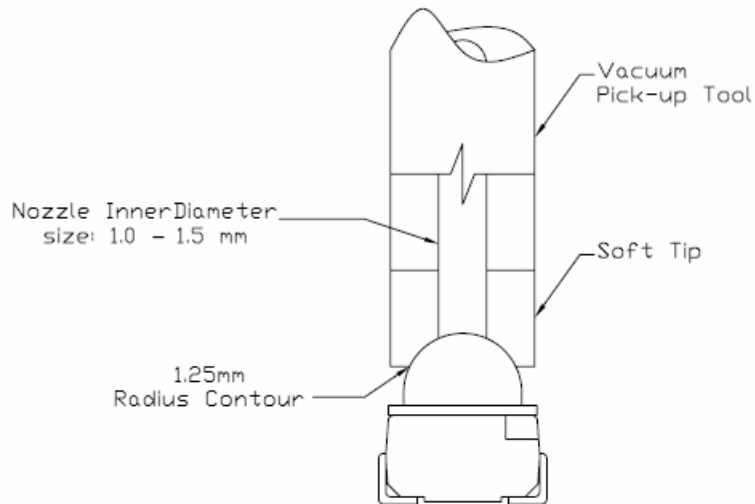

Figure 12. Soft Tip Vacuum Pick-up Tool for extracting SMT LED Components from Carrier Tape.

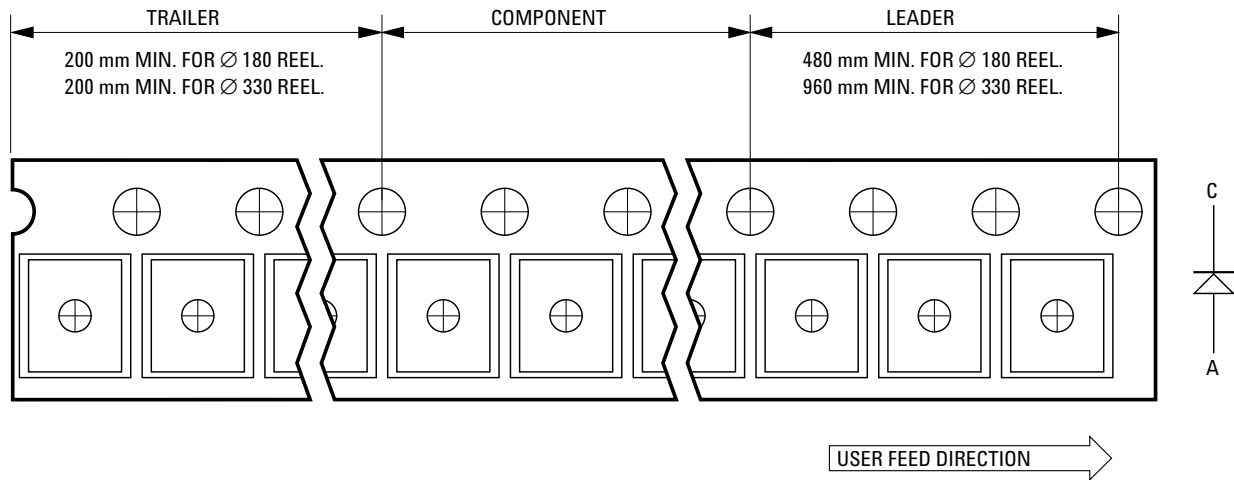

Figure 13. Tape Leader and Trailer Dimensions.

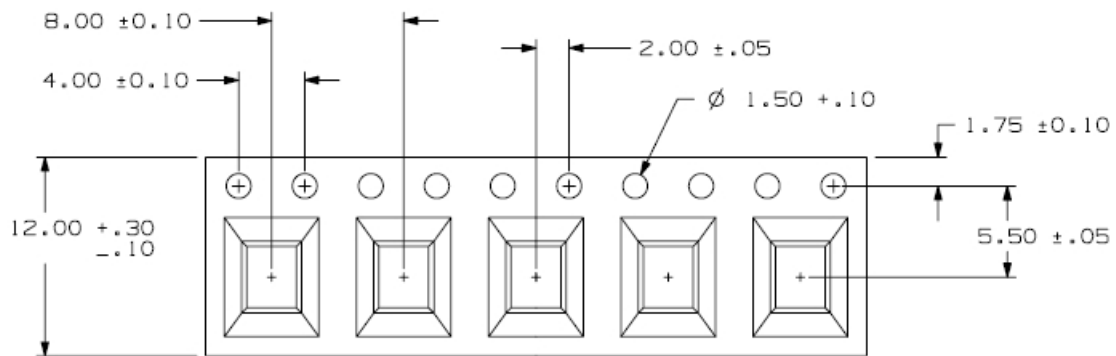

Figure 14. Tape Dimensions.

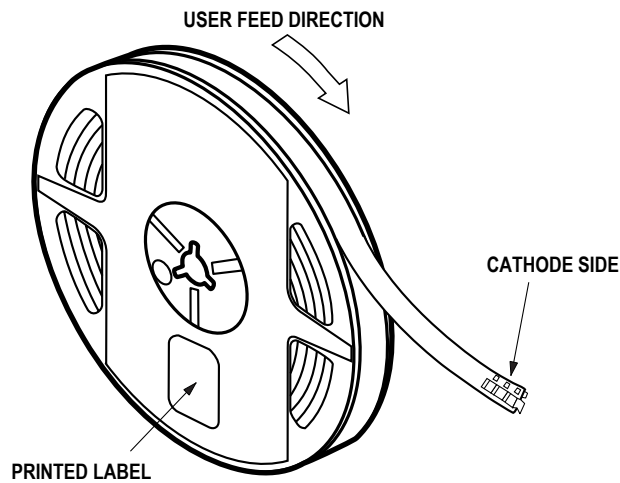

Figure 15. Reeling Orientation.

## Moisture Sensitivity

This product is qualified as Moisture Sensitive Level xx per Jedec J-STD-020. Precautions when handling this moisture sensitive product is important to ensure the reliability of the product. Do refer to Avago Application Note AN5305 Handling of Moisture Sensitive Surface Mount Devices for details.

### A. Storage before use

- Unopen moisture barrier bag (MBB) can be stored at <math><40^{\circ}\text{C}/90\%\text{RH}</math> for 12 months. If the actual shelf life has exceeded 12 months and the HIC indicates that baking is not required, then it is safe to reflow the LEDs per the original MSL rating.
- It is not recommended to open the MBB prior to assembly (e.g. for IQC).

### B. Control after opening the MBB

- The humidity indicator card (HIC) shall be read immediately upon opening of MBB.
- The LEDs must be kept at <math><30^{\circ}\text{C} / 60\%\text{RH}</math> at all time and all high temperature related process including soldering, curing or rework need to be completed within 672 hours.

### C. Control for unfinished reel

- For any unuse LEDs, they need to be stored in sealed MBB with desiccant or desiccator at <math><5\%\text{RH}</math>.

### D. Control of assembled boards

- If the PCB soldered with the LEDs is to be subjected to other high temperature processes, the PCB need to be stored in sealed MBB with desiccant or desiccator at <math><5\%\text{RH}</math> to ensure no LEDs have exceeded their floor life of 672 hours.

### E. Baking is required if:

- "10%" or "15%" HIC indicator turns pink.
- The LEDs are exposed to condition of <math>>30^{\circ}\text{C} / 60\% \text{RH}</math> at any time.
- The LEDs floor life exceeded 672 hours.

Recommended baking condition:  $60\pm 5^{\circ}\text{C}$  for 20 hours.



### Intensity Bin Select (X<sub>5</sub>X<sub>6</sub>)

Individual reel will contain parts from one half bin only

#### X<sub>5</sub> Min IV Bin

X <sub>6</sub>	
0	Full Distribution
2	2 half bins starting from X <sub>5</sub> 1
3	3 half bins starting from X <sub>5</sub> 1
4	4 half bins starting from X <sub>5</sub> 1
5	5 half bins starting from X <sub>5</sub> 1
6	2 half bins starting from X <sub>5</sub> 2
7	3 half bins starting from X <sub>5</sub> 2
8	4 half bins starting from X <sub>5</sub> 2
9	5 half bins starting from X <sub>5</sub> 2

#### Intensity Bin Limits

Bin ID	Min. (mcd)	Max. (mcd)
U1	450.00	560.00
U2	560.00	715.00
V1	715.00	900.00
V2	900.00	1125.00
W1	1125.00	1400.00
W2	1400.00	1800.00
X1	1800.00	2240.00
X2	2240.00	2850.00
Y1	2850.00	3550.00
Y2	3550.00	4500.00
Z1	4500.00	5600.00
Z2	5600.00	7150.00
11	7150.00	9000.00
12	9000.00	11250.00
21	11250.00	14000.00
22	14000.00	18000.00

Tolerance of each bin limit = ± 12%

### Color Bin Select (X<sub>7</sub>)

Individual reel will contain parts from one full bin only.

#### X<sub>7</sub>

0	Full Distribution
Z	A and B only
Y	B and C only
W	C and D only
V	D and E only
U	E and F only
Q	A, B and C only
P	B, C and D only
N	C, D and E only
M	D, E and F only
1	A, B, C and D only
3	B, C, D and E only
4	C, D, E and F only
5	A, B, C, D and E only
6	B, C, D, E, and F only

#### Color Bin Limits

Amber	Min. (nm)	Max. (nm)
A	582.0	584.5
B	584.5	587.0
C	587.0	589.5
D	589.5	592.0
E	592.0	594.5
F	594.5	597.0

Orange	Min. (nm)	Max. (nm)
A	597.0	600.0
B	600.0	603.0
C	603.0	606.0
D	606.0	609.0
E	609.0	612.0

Red	Min. (nm)	Max. (nm)
Full Distribution	620.0	635.0

Tolerance of each bin limit = ±1nm

### Packaging Option (X<sub>8</sub> X<sub>9</sub>)

Option	Test Current	Package Type	Reel Size
M1	50mA	Top Mount	7

### VF Bin Limits

Bin ID	Min.	Max.
VA	1.9	2.2
VB	2.2	2.5
VC	2.5	2.8
VD	2.8	3.1
VE	3.1	3.4

Tolerance of each bin limit =  $\pm 0.1V$

For product information and a complete list of distributors, please go to our web site: [www.avagotech.com](http://www.avagotech.com)

Avago, Avago Technologies, and the A logo are trademarks of Avago Technologies, Limited in the United States and other countries. Data subject to change. Copyright © 2007 Avago Technologies Limited. All rights reserved.

AV02-0529EN - June 26, 2007

